

Dump Pit

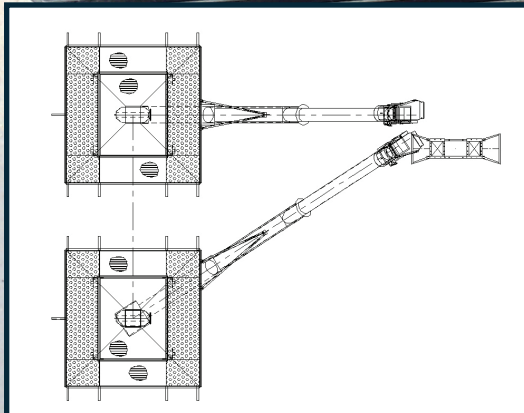

Double Pit System

ONE PIECE WELDED CONSTRUCTION WITH DRIVE-OVER SURFACE—BUILT TO LAST

The drive-over Lowry DumPit was designed with the goal of increasing the speed, safety and ease of harvesting. DumPits can be set up to move all the grain from the pit into a holding bin within a matter of a few minutes and be ready for the next truckload. The Lowry DumPit has proven to last for several harvest seasons with minimal maintenance.

Quality:

- ◆ Keeps grain in and water out
- ◆ Underground coating system with resin coated welded seams
- ◆ 10 gauge sides, 7 gauge hopper, 3/16" deck plate with extra stiffeners
- ◆ Double thickness of flight at intake
- ◆ Moving parts safely enclosed
- ◆ Over 30 years of development to achieve high standards of design

Efficiency and Capacity:

- ◆ Unload entire truck in matter of a few minutes
- ◆ Sized from 22 bushels to 650 bushels, with optional arrangement of double pit system
- ◆ Double pit system holds up to 1,300 bushels
- ◆ Large holding capacity allows for smaller leg and down spouts
- ◆ Multiple grate options allow match to unloading area

Outstanding Features:

- ◆ Auger chamber allows ease of flight and tube replacement
- ◆ Selection of auger sizes to compliment bushels per hour of grain leg or other take-away
- ◆ Ease of backfilled installation with sump pump to control water level
- ◆ Inlet chutes for additional access to pit
- ◆ Motor controls available including automatic shut-off
- ◆ Delivery and crane service available for unloading pit at site

STANDARD DUMPIT EQUIPMENT & FEATURES

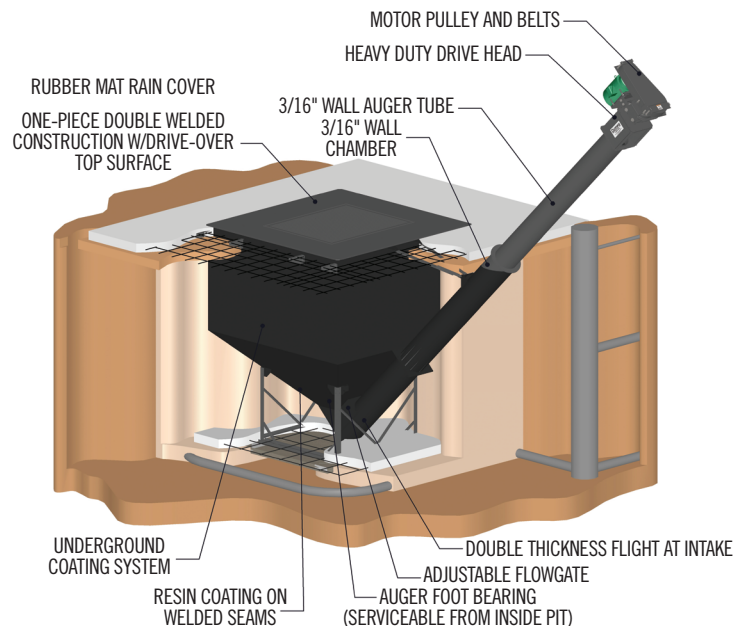

Helping you succeed in a competitive market!

Lowry, MN 56349
 320.283.5450 ♦ 800.950.4792
 info@lowrymfgco.com ♦ www.lowrymfgco.com

*Go online to find your closest dealer.
www.lowrymfgco.com
 Click on: Find a Lowry Dealer.*